

# PRECISION

## TURBO & ENGINE

Precision Turbo & Engine 616A South Main Street P.O. Box 425 46341-0425  
Phone (855) 996-7832 Fax (219) 996-7749 Web: [www.precisionturbo.net](http://www.precisionturbo.net)

Thank you for purchasing our PB64 64mm Blow Off Valve (BOV). With over 100 years of combined turbocharger development and racing experience, we at Precision Turbo & Engine take great pride in providing you with the best BOV on the market today and expect that it brings you many years of exceptional performance.

Made from lightweight 6061 and 7075 billet aluminum, our 64mm BOV is satin black anodized to be aesthetically pleasing yet functional while offering long-lasting protection from the elements. It also features a Kevlar-reinforced silicon rolling diaphragm for quick response and a hard coat anodized valve stem for enhanced durability. The PB64 also has a Computational Fluid Dynamics (CFD) designed valve and valve body for the highest flow even at low lift, while the attached O-ring seal prevents leakage. Furthermore, your new PB64 BOV also utilizes an innovative and industry-first proprietary wave spring for added weight savings while still holding the valve closed under high vacuum idling.

Included you will find your new PB64 BOV, a weld-on 6061 aluminum mounting flange, a spring adjustment screw, and 2 top ports for the ultimate in versatility and adjustability. The PB64 is generally compatible with most aftermarket manual and electronic boost controllers on the market today. If you have any questions or need any technical support, our Technical Sales Staff is here to help!



## Installation Instructions

Note: The optimum mounting and placement of your new PB64 blow off valve will be determined by your charge pipe configuration. These notes should be considered when installing your new blow off valve.

- In order to assure proper boost control, your PB64 blow off valve needs to be welded at a smooth transitional angle with the charge flow. Ninety degree mounting onto charge pipe tubing is acceptable, but not recommended. Refer to diagrams below.
- Mounting flange is aluminum and is compatible with most aluminum charge pipe tubing.
- It is recommended to secure all vacuum and or boost control hoses securely with zip ties or cushioned clamps. Route all vacuum hoses away from high heat sources such as the turbine housing and exhaust manifold.
- Use caution when working on a hot engine. Blow off valves and turbocharger components are **EXTREMELY HOT** and can cause severe burns.

### **RECOMMENDED- Add Plug with Assembly**

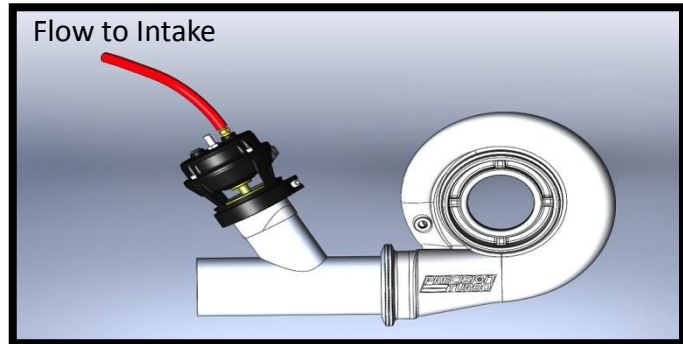
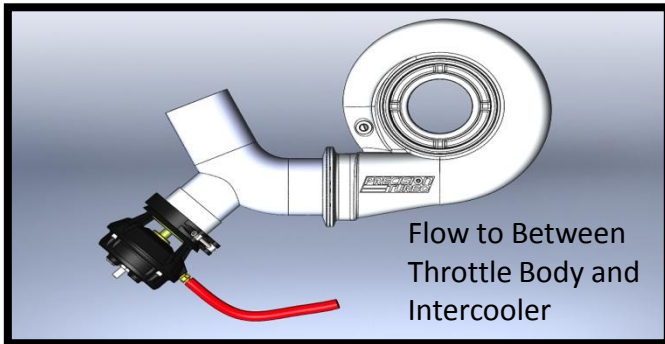

### **ACCEPTABLE**

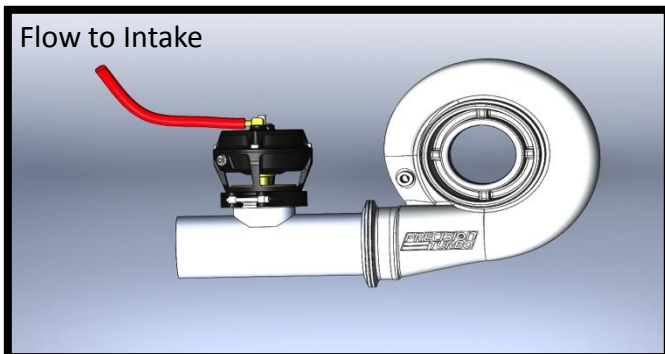

### **NOT RECOMMENDED**

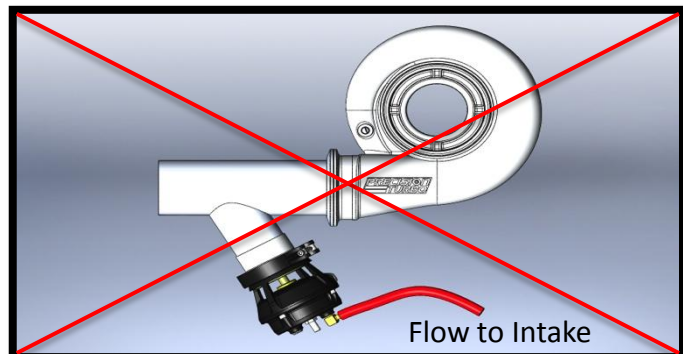

**Replacement Parts**

<b>PART NUMBER</b>	<b>QUANTITY</b>	<b>DESCRIPTION</b>
PBO083-2010	1	PTE 64MM RACE BOV
BV60101	1	VALVE ASSEMBLY KIT (VALVE & O-RING)
BV60104	1	CLAMP ASSEMBLY (CLAMP, MS XSHCS 0.8 X 45, BARREL NUT, & CLAMP BUSHING)
BV60108	1	BOV64 MOUNTING FLANGE KIT (FLANGE & MOUNTING O-RING)
BV60009	1	VALVE SEAT



**Operational Overview**

Your PB64 BOV, releases charge pressure that backs up when the throttle is closed. The purpose of your new PB64 BOV is to prevent surge and/or compressor stall and reduce premature wear on your turbocharger. Pressure differential between intake manifold and charge pipe, in conjunction with spring pressure, control the opening of the BOV. Once the spring rate has been overcome, the valve will open.

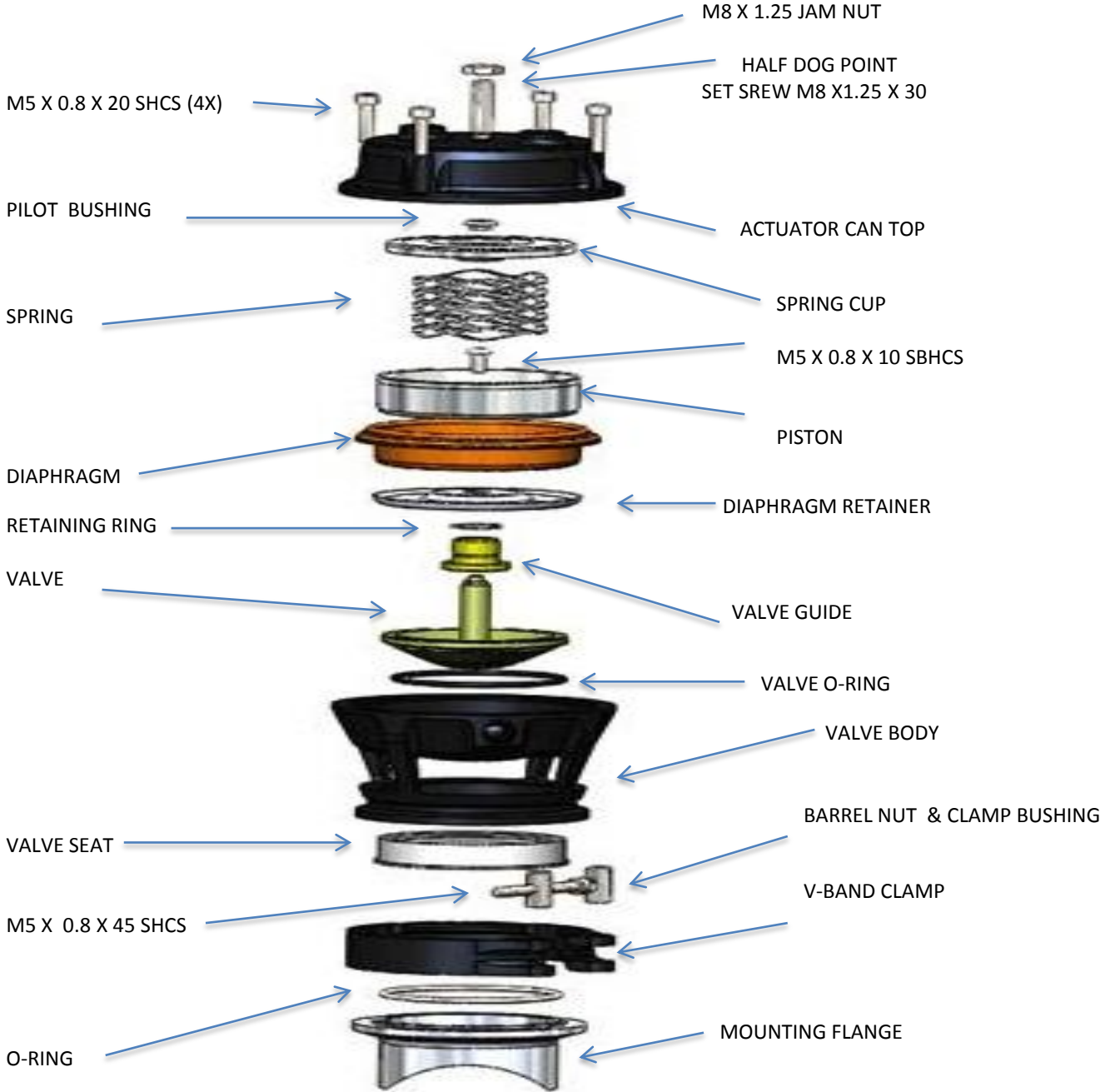



## **WARRANTY**

Each Precision Turbo PB64 blow off valve is warranted to be free from manufacturer's defect for a period of 12 months or 12,000 miles, whichever occurs first from the date of the original invoice. Manufacturer's warranty otherwise applies. Seller expressly disclaims all implied warranties of merchantability and or fitness for a particular purpose.

Precision Turbo will repair or replace, at its discretion, any Precision Turbo branded product that proves defective in material or workmanship under normal installation, use and service. In the case of any warranty claim with regards to defects in material or workmanship, the product in question should be returned, freight prepaid to the address shown below.

This warranty does not cover damage or failure of components due to normal wear and tear. There is no warranty on any parts used in race applications, or on products that have been physically altered, improperly installed or not maintained. Seller's warranty is in lieu of all other warranties, expressed or implied.

## **RETURNS**

Returns for credit or exchange are allowable only with a Returned Goods Authorization (RGA) number for 30 days from date of shipment. RGA numbers can be obtained directly from Precision Turbo and Engine. Additionally, the Product Return Form (found on our website, [www.precisionturbo.net](http://www.precisionturbo.net)) must be filled out in its entirety, and returned with the product being sent back for credit or exchange. Restocking fees may apply. Product must be new or in resalable condition and returned at the customers expense freight prepaid. All claims for shipping damage must be addressed with the carrier by the customer.

## **DISCLAIMER**

Precision Turbo does not warrant the accuracy or completeness of the information contained in the manual. Any information and specifics contained in the manual are provided "as is" without any representation or warranty, expressed or implied, of any kind, including, but not limited to, warranties of merchantability, non-infringement, or fitness for any particular purpose. Some jurisdictions do not allow for the exclusion of implied warranties, so the above exclusions may not apply to you.

Federal, State or provincial laws, rules and regulations in the US, Canada or elsewhere may prohibit the removal or modification of components that were installed on motor vehicles or engines by the original equipment manufacturer, in order to meet emissions requirements or to comply with safety regulations applicable to engines or vehicles manufactured for use on public roads or highways. Removal of such components and installation of Precision Turbo products may be illegal and considered to be emissions-related tampering under applicable laws, rules and regulations. Motor vehicles or engines equipped with Precision Turbo products may not be used on public roads or highways, as installation of such products could cause the vehicles engine to be non-compliant with applicable emissions and or safety standards.

Installation of Precision Turbo products (or similar products from other manufacturers) on a motor vehicle or engine, may void, reduce or otherwise adversely affect any warranties given by the manufacturer or seller of the vehicle, engine or other component parts.

**Precision Turbo & Engine 616A South Main Street P.O. Box 425 46341-0425**  
**Phone (855) 996-7832 Fax (219) 996-7749 Web: [www.precisionturbo.net](http://www.precisionturbo.net)**